



YORK HEAVY DUTY CYLINDERS



OEM HYDRAULIC CYLINDER SPECIALISTS



HEAVY DUTY YORK - CROSS TUBE

RAM YORK Heavy Duty Cross Tube is a high quality welded cylinder designed for heavy loads and extreme duty. The rod and base ends are welded cross tubes with grease zerks. Designed to last, this cylinder has a heavy duty piston with high pressure seal and wear ring and a over sized piston stem. The internally threaded gland reduces the cross section and features wear rings to reduce friction and increase rod support. The gland is easily removed for maintenance. YORK Heavy Duty cylinders are well suited for equipment in construction, agricultural, oil and gas sector, waste/recycling and transportation.

STANDARD FEATURES

Intended Use:	Double acting applications	Piston Locknut:	High tensile grade C
Rated Pressure:	3000 PSI	End Mounts:	Cross tube
Rod Material:	High tensile SAE C1045, ground and polished hard chrome plated	Ports:	SAE
Barrel Material:	High tensile SAE C1026/St52.3 cold drawn tube precision honed for extended seal life	Port Plugs:	High quality steel
Gland Material:	Ductile iron 65-45-12 (ASTM A536)	Internal Seals:	North American
Piston Material:	Ductile iron 65-45-12 (ASTM A536)	Paint Finish:	2 part urethane black
		Testing:	100% full cycle tested

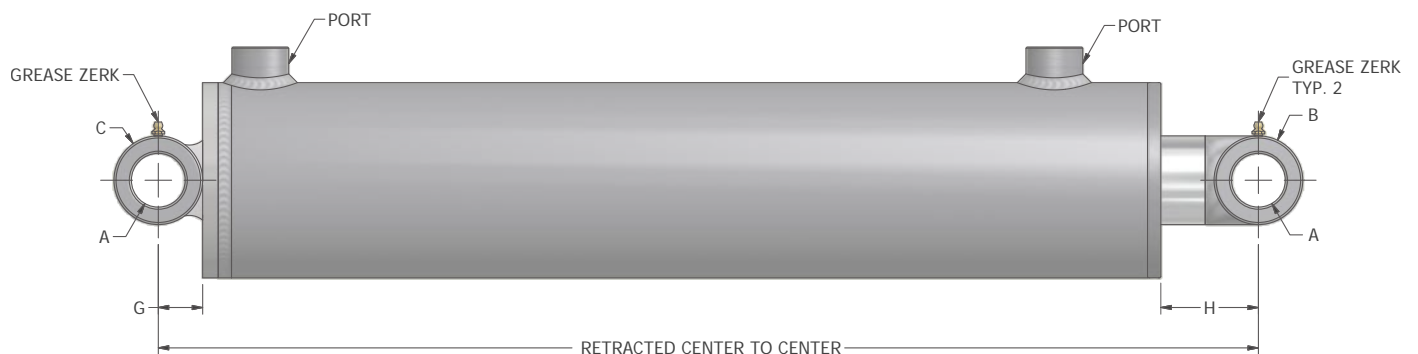

Bore (inches)	A	B	C	D	E	F	G	H	Ports
5.00	1.515	2.50	2.50	5.75	4.00	5.50	1.25	2.75	SAE-12
6.00	1.515	2.50	2.50	6.75	4.00	6.50	1.25	2.75	SAE-12
8.00	2.515	4.00	4.00	9.00	5.00	8.75	2.00	3.50	SAE-16

Measurements for A, B, C, D, E, F, G, H are in inches.

All specifications are subject to change without notice.

Bore (inches)	RAM Part Number	Stroke (inches)	Rod Diameter (inches)	Pin Center to Center (inches)		Ports	Pin Diameter Nominal (inches)	Maximum Rated Pressure & Column Load on Full Extension		Shipping Weight (lbs)
				Retracted	Extended			Pressure (PSI)	Load (lbf)	
5.00	R4508545	8	2.500	19	27	SAE-12	1.500	3000	58900	68
	R4508546	12		23	35					79
	R4508547	16		27	43					89
	R4508548	20		31	51					99
	R4508549	24		35	59			109		
	R4508550	30		41	71			124		
	R4508551	36		47	83			140		
	R4508552	48		61	109			178		
	R4508553	54		68	122			197		
	R4508554	60		75	135			217		
6.00	R4508555	8	3.000	19	27	SAE-12	1.500	3000	84823	88
	R4508556	12		23	35					101
	R4508557	16		27	43					115
	R4508558	20		31	51					128
	R4508559	24		35	59			142		
	R4508560	30		41	71			163		
	R4508561	36		47	83			183		
	R4508562	48		61	109			234		
	R4508563	54		68	122			259		
	R4508564	60		75	135			285		
8.00	R4508796	8	4.000	24	32	SAE-16	2.500	3000	150795	250
	R4508797	12		28	40					275
	R4508798	16		32	48					300
	R4508799	20		36	56					325
	R4508800	24		40	64					350
	R4508801	30		46	76					385
	R4508802	36		52	88					425
	R4508803	48		66	114					500
	R4508804	54		73	127					540
	R4508805	60		80	140					580

All specifications are subject to change without notice.
All weights are approximate shipping weights.



HEAVY DUTY YORK - CLEVIS

RAM YORK Heavy Duty Clevis is a high quality welded cylinder designed for heavy loads and extreme duty. The rod and base ends are welded high strength steel clevises. Designed to last, this cylinder has a heavy duty piston with high pressure seal and wear ring and an over sized piston stem. The internally threaded gland reduces the cross section and features wear rings to reduce friction and increase rod support. The gland is easily removed for maintenance. YORK Heavy Duty cylinders are well suited for equipment in construction, agricultural, oil and gas sector, waste/recycling and transportation.

STANDARD FEATURES

Intended Use:	Double acting applications	Piston Locknut:	High tensile grade C
Rated Pressure:	3000 PSI	End Mounts:	Clevis
Rod Material:	High tensile SAE C1045, ground and polished hard chrome plated	Ports:	SAE
Barrel Material:	High tensile SAE C1026/St52.3 cold drawn tube precision honed for extended seal life	Port Plugs:	High quality steel
Gland Material:	Ductile iron 65-45-12 (ASTM A536)	Internal Seals:	North American
Piston Material:	Ductile iron 65-45-12 (ASTM A536)	Paint Finish:	2 part urethane black
		Testing:	100% full cycle tested

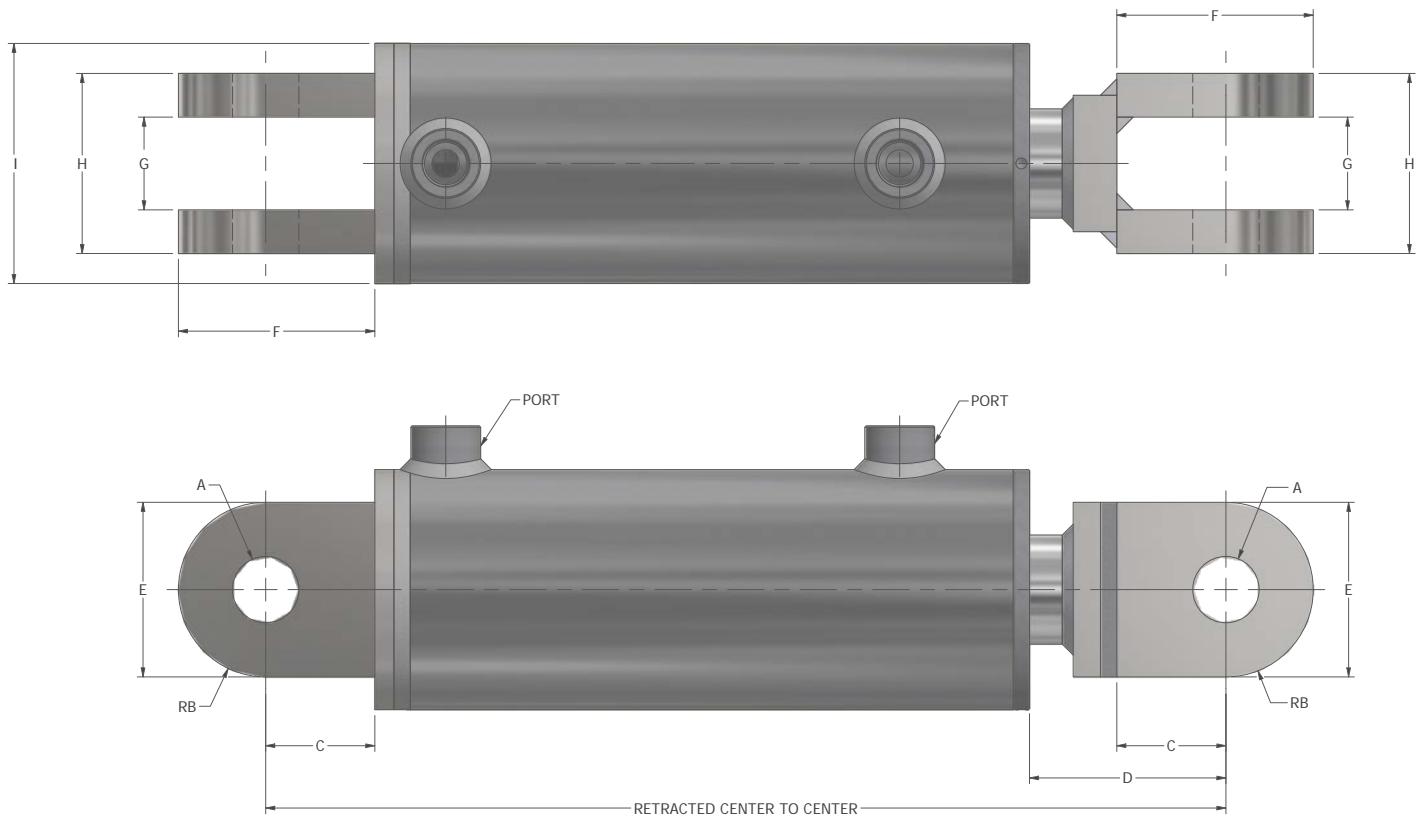

**HEAVY DUTY YORK
CLEVIS CYLINDERS**

Bore (inches)	A	B	C	D	E	F	G	H	I	Ports
5.00	1.515	2.00	2.50	4.50	4.00	4.50	2.13	4.13	5.50	SAE-12
6.00	1.515	2.00	2.50	4.50	4.00	4.50	2.13	4.13	6.50	SAE-12
8.00	2.515	3.00	3.50	6.00	6.00	6.50	3.13	6.13	8.75	SAE-16

Measurements for A, B, C, D, E, F, G, H, I are in inches.

All specifications are subject to change without notice.

Bore (inches)	RAM Part Number	Stroke (inches)	Rod Diameter (inches)	Pin Center to Center (inches)		Ports	Pin Diameter Nominal (inches)	Maximum Rated Pressure & Column Load on Full Extension		Shipping Weight (lbs)
				Retracted	Extended			Pressure (PSI)	Load (lbf)	
5.00	R4509389	8	2.500	22	30	SAE-12	1.500	3000	58900	87
	R4509390	12		26	38					98
	R4509391	16		30	46					108
	R4509392	20		45	65					118
	R4509393	24		38	62					128
	R4509394	30		44	74					143
	R4509395	36		50	86					159
	R4509396	48		64	112					197
	R4509397	54		71	125					216
	R4509398	60		78	138					236
6.00	R4509399	8	3.000	22	30	SAE-12	1.500	3000	84823	107
	R4509400	12		26	38					120
	R4509401	16		30	46					134
	R4509403	20		45	65					147
	R4509404	24		38	62					161
	R4509405	30		44	74					182
	R4509406	36		50	86					202
	R4509407	48		64	112					253
	R4509408	54		71	125					278
	R4509409	60		78	138					304
8.00	R4509410	8	4.000	28	36	SAE-16	2.500	3000	150795	299
	R4509411	12		32	44					324
	R4509412	16		36	52					349
	R4509413	20		40	60					374
	R4509414	24		44	68					399
	R4509415	30		50	80					434
	R4509416	36		56	92					474
	R4509417	48		70	118					549
	R4509418	54		77	131					589
	R4509419	60		84	144					629

All specifications are subject to change without notice.
All weights are approximate shipping weights.



RAM Industries Inc.

PO Box 5007 33 York Rd E Yorkton, SK S3N3Z4 Canada

T: 1-877-799-1005 • F: (306) 786-2651

www.ramindustries.com • sales@ramindustries.com

www.linkedin.com/company/ram-industries-inc



www.ramindustries.com

Hydraulic Cylinder Design & Manufacturing • Precision Custom Machining