



RAMLOK WIRELOCK CYLINDERS



OEM HYDRAULIC CYLINDER SPECIALISTS



RAMLOK® WIRELOCK

The 3000 PSI rated RAMLOK® Hydraulic cylinders feature a unique construction technology that incorporates premium materials such as high tensile cold drawn tube while also utilizing unique production methods. For ease of maintenance the featured RAMLOK® internal steel rings securely lock the cylinder barrel to the head and base. This restricts movement within the cylinder allowing for quick and easy service access for seal replacement and cylinder maintenance.

RAMLOK® standard models have a bore size of 1/2" increments from 2" up to 4" and stroke ranges of 4" up to 26". Port alignment can be changes according to customer requirements.

Replacement parts and seal kits are readily available.

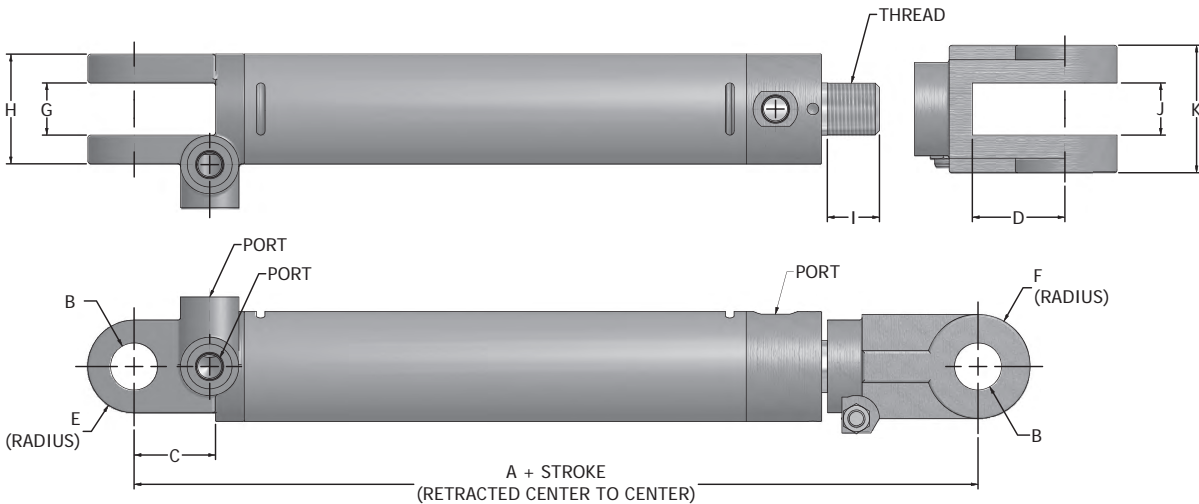

Bore	A	B	C	D	E	F	G	H	I	J	K	Ports	Threads
2.00	10.25*	1.015	1.88	2.00	1.00	1.13	1.13	2.50	1.13	1.13	2.75	SAE-6	1.125 - 12 UNF
2.50	10.25*	1.015	1.88	2.00	1.00	1.13	1.13	2.63	1.13	1.13	2.75	SAE-6	1.125 - 12 UNF
3.00	10.25*	1.015	1.88	2.00	1.00	1.13	1.13	2.63	1.13	1.13	2.75	SAE-8	1.250 - 12 UNF
3.50	10.25*	1.015	1.88	2.00	1.13	1.13	1.13	2.63	1.13	1.13	2.75	SAE-8	1.250 - 12 UNF
4.00	10.25*	1.015	1.88	2.00	1.13	1.13	1.13	2.81	1.13	1.13	2.75	SAE-8	1.250 - 12 UNF

Measurements for A, B, C, D, E, F, G, H, I, J, K are in inches.

All specifications are subject to change without notice.

*For the standard ASAE (8" stroke) cylinders this dimension is 12.25".

STANDARD FEATURES

Intended Use: Double acting applications

Rated Pressure: 3000 PSI

Rod Material: High tensile SAE C1045,
ground and polished hard chrome plated

Barrel Material: High tensile SAE C1026
St52.3 cold drawn tube precision honed
for extended seal life

Gland Material: Ductile iron 65-45-12 (ASTM A536)

Piston Material: Ductile iron 65-45-12 (ASTM A536)

Piston Locknut: High tensile grade C

Pin & Pin Clip: High tensile zinc-plated steel

End Mounts: Female clevises

Clevis Clamp: Grade 8 bolt and nut

Ports: SAE

Port Plugs: High quality steel

Internal Seals: North American

Paint Finish: 2 part urethane black

Testing: 100% full cycle tested

Bore (inches)	RAM Part Number	Stroke (inches)	Rod Diameter (inches)	Pin Center to Center (inches)		Ports	Pin Diameter Nominal (inches)	Maximum Rated Pressure & Column Load on Full Extension		Shipping Weight (lbs)
				Retracted	Extended			Pressure (PSI)	Load (lbf)	
2.00	R4505548C	4	1.125	14.25	18.25	SAE-6	1.000	3000	9425	14
	R4505549C	6	1.125	16.25	22.25					15
	R4505550C	8	1.125	18.25	26.25					16
	R4505551C*	8	1.125	20.25	28.25					16.5
	R4505552C	10	1.125	20.25	30.25					18
	R4505553C	12	1.125	22.25	34.25					19
	R4505554C	14	1.125	24.25	38.25			20		
	R4505555C	16	1.125	26.25	42.25			21		
	R4505556C	18	1.125	28.25	46.25			22		
	R4505557C	20	1.125	30.25	50.25			23		
	R4505558C	24	1.125	34.25	58.25			27		
	R4505559C	30	1.125	40.25	70.25			32		
R4505560C	36	1.125	46.25	82.25	37					
2.50	R4505561C	4	1.125	14.25	18.25	SAE-6	1.000	3000	14726	15
	R4505562C	6	1.125	16.25	22.25					17
	R4505563C	8	1.125	18.25	26.25					19
	R4505564C*	8	1.125	20.25	28.25					19.5
	R4505565C	10	1.125	20.25	30.25					21
	R4505566C	12	1.125	22.25	34.25					23
	R4505567C	14	1.125	24.25	38.25			25		
	R4505568C	16	1.250	26.25	42.25			27		
	R4505569C	18	1.250	28.25	46.25			29		
	R4505570C	20	1.250	30.25	50.25			31		
	R4505571C	24	1.250	34.25	58.25			34		
	R4505572C	30	1.250	40.25	70.25			39		
	R4505573C	36	1.250	46.25	82.25			44		

*Conforms to ASAE (American Society of Agricultural Engineers) specifications.

All specifications are subject to change without notice.
All weights are approximate shipping weights.

Bore (inches)	RAM Part Number	Stroke (inches)	Rod Diameter (inches)	Pin Center to Center (inches)		Ports	Pin Diameter Nominal (inches)	Maximum Rated Pressure & Column Load on Full Extension		Shipping Weight (lbs)
				Retracted	Extended			Pressure (PSI)	Load (lbf)	
3.00	R4505574C	4	1.250	14.25	18.25	SAE-8	1.000	3000	21205	18
	R4505575C	6	1.250	16.25	22.25					21
	R4505576C	8	1.250	18.25	26.25					25
	R4505577C*	8	1.250	20.25	28.25					25.5
	R4505578C	10	1.250	20.25	30.25					28
	R4505579C	12	1.250	22.25	34.25					30
	R4505580C	14	1.250	24.25	38.25					32
	R4505581C	16	1.500	26.25	42.25					35
	R4505582C	18	1.500	28.25	46.25					37
	R4505583C	20	1.500	30.25	50.25			39		
	R4505584C	24	1.500	34.25	58.25			2500	17671	43
R4505585C	30	1.500	40.25	70.25	1722	12175	49			
R4505586C	36	1.500	46.25	82.25	1258	8895	55			
3.50	R4505587C	4	1.250	14.25	18.25	SAE-8	1.000	3000	28863	28
	R4505588C	6	1.250	16.25	22.25					30
	R4505589C	8	1.250	18.25	26.25					32
	R4505590C*	8	1.250	20.25	28.25					32.5
	R4505591C	10	1.250	20.25	30.25					34
	R4505592C	12	1.250	22.25	34.25					36
	R4505593C	14	1.250	24.25	38.25			2391	23004	38
	R4505594C	16	1.500	26.25	42.25			3000	28863	45
	R4505595C	18	1.500	28.25	46.25			2776	26709	49
	R4505596C	20	1.500	30.25	50.25			2036	19585	53
	R4505597C	24	1.500	34.25	58.25			1378	13255	59
	R4505598C	30	1.500	40.25	70.25			994	9563	65
	R4505599C	36	1.500	46.25	82.25					
4.00	R4505600C	4	1.375	14.25	18.25	SAE-8	1.000	3000	37699	32
	R4505601C	6	1.375	16.25	22.25					35
	R4505602C	8	1.375	18.25	26.25					38
	R4505603C*	8	1.375	20.25	28.25					38.5
	R4505604C	10	1.375	20.25	30.25					40
	R4505605C	12	1.375	22.25	34.25					43
	R4505606C	14	1.375	24.25	38.25			2680	33680	46
	R4505607C	16	1.750	26.25	42.25			3000	37699	52
	R4505608C	18	1.750	28.25	46.25					56
	R4505609C	20	1.750	30.25	50.25					59
	R4505610C	24	1.750	34.25	58.25					2887
	R4505611C	30	1.750	40.25	70.25			1954	24556	76
	R4505612C	36	1.750	46.25	82.25			1410	17716	86

*Conforms to ASAE (American Society of Agricultural Engineers) specifications.

All specifications are subject to change without notice.
All weights are approximate shipping weights.



RAM INDUSTRIES INC.

PO Box 5007 33 York Rd E Yorkton, SK S3N3Z4 Canada

T: 1-877-799-1005 • F: (306) 786-2651

www.ramindustries.com • sales@ramindustries.com

www.linkedin.com/company/ram-industries-inc



www.ramindustries.com

Hydraulic Cylinder Design & Manufacturing • Precision Custom Machining